

Detalles Técnicos Technical Details	Speed RPM	Square Drive	Max. Torque Nm/ft-lb	Length mm/inch	Weight kg/lb	Air Consumption LPM / CFM	Air Inlet inch	Working Pressure Bar / PSI
28203	3,500	1	2.7 10(2,000)	300(11.8)	9.6(21.1)	311(11)	1/2	6.3 (90)

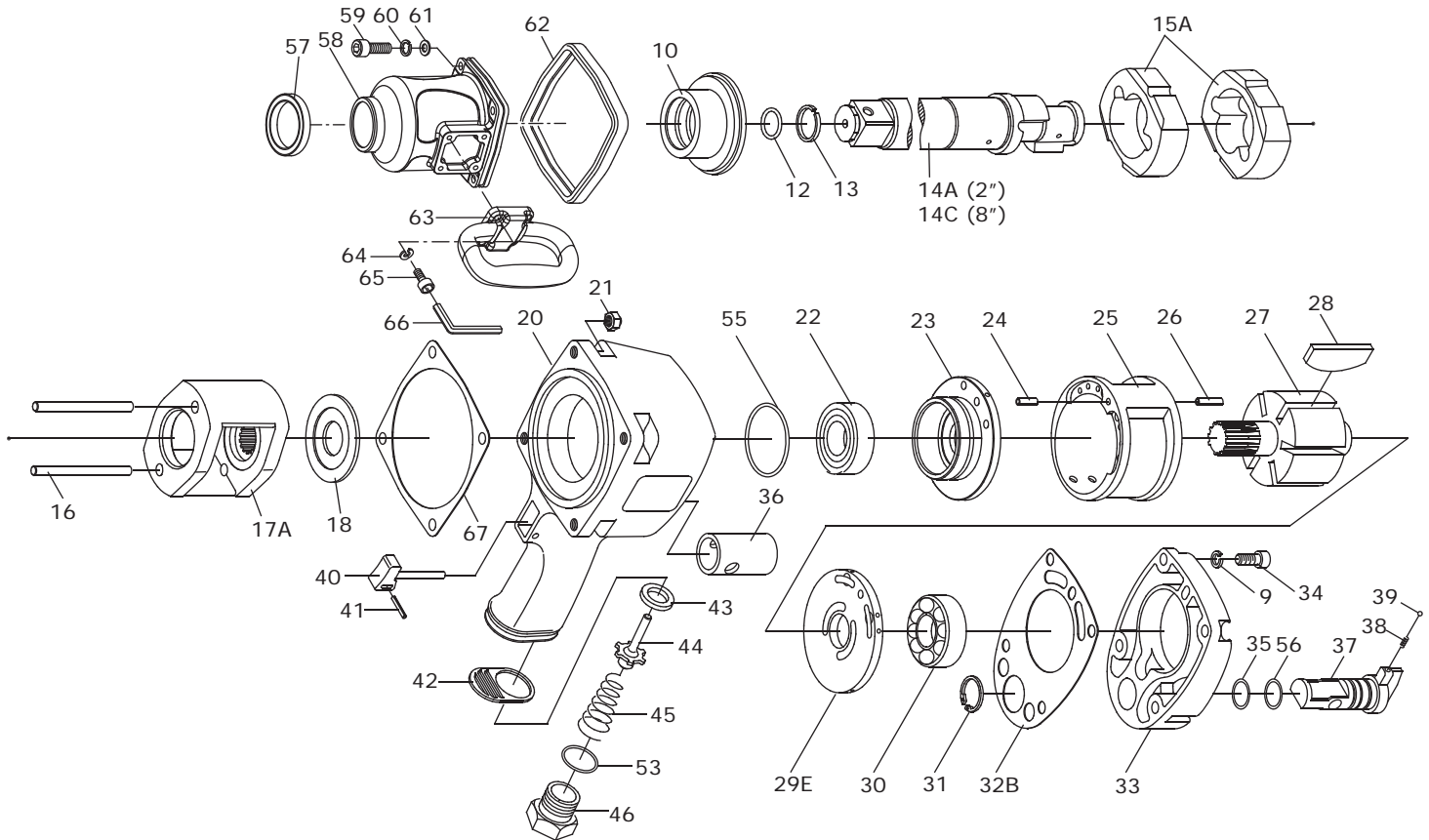

* Due to our continuous improvement, all specifications are subject to change without prior notice.

Index No.	Description	Quantity	Index No.	Description	Quantity	Index No.	Description	Quantity
9	Spring Washer	4	28	Rotor Blade	6	45	Spring	1
10	Bushing	1	29E	Rear End Plate	1	46	Air Inlet	1
12	O-Ring	1	30	Ball Bearing	1	53	O-Ring	1
13	Anvil collar	1	31	Snap Ring	1	55	O-Ring	1
14A	Anvil	1	32B	Rear Gasket	1	56	O-Ring	1
15A	Hammer	2	33	Rear Cover	1	57	Oil Seal	1
16	Hammer Pin	2	34	Cap Screw	4	58	Hammer Case	1
17A	Hammer Cage	1	35	O-Ring	1	59	Cap Screw	4
18	Rear Washer	1	36	Valve Sleeve	1	60	Spring Washer	4
20	Housing	1	37	Reverse Valve	1	61	Washer	4
21	Lock Nut	4	38	Spring	1	62	Housing Band	1
22	Ball Bearing	1	39	Steel Ball	1	63	D-Type Handle	1
23	Front End Plate	1	40	Trigger	1	64	Spring Washer	4
24	Spring Pin	1	41	Spring Pin	1	65	Cap Screw	4
25	Cylinder	1	42	Exhaust Deflector	1	66	Hex. Wrench	1
26	Spring Pin	1	43	Bushing	1	67	Front Gasket	1
27	Rotor	1	44	Valve Stem	1			