

Détalles Técnicos Technical Details	Speed RPM	Wheel mm/inch	Flange Size mm	Spindle Size	Power KW/HP	Length mm/inch	Weight kg/lb	Air Consumption LPM / CFM	Air Inlet inch	Vibration m/s ²	Sound Pressure dB(A)	Sound Power dB(A)	Working Pressure Bar / PSI
75105	7,600	178 (7)	40	5/8	1.5 (2.0)	253 (10.0)	3.8 (8.3)	225 (7.9)	3/8	4.39	89.4/100.4	6.3 (90)	

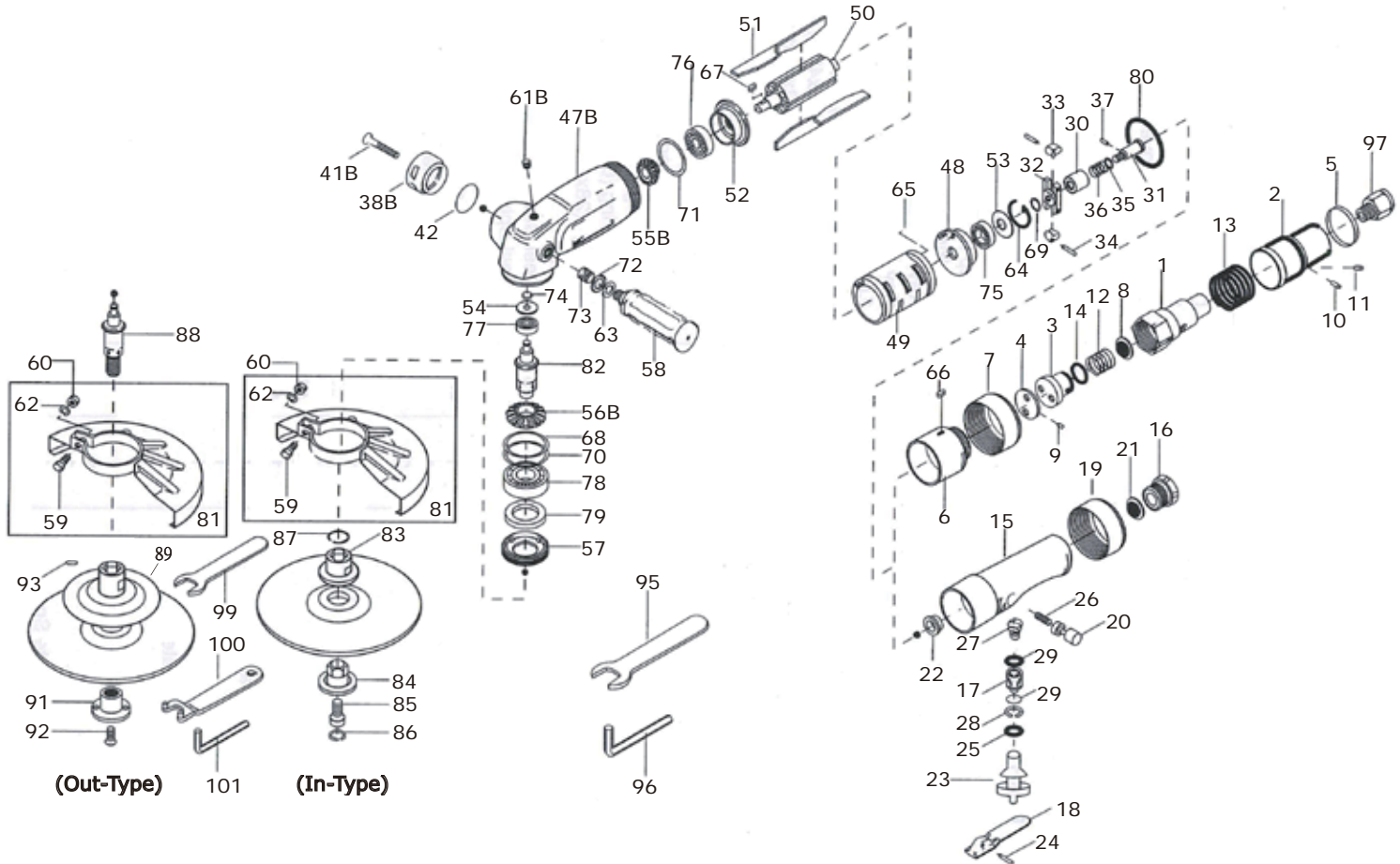

Index No.	Description	Quantity	Index No.	Description	Quantity	Index No.	Description	Quantity
1	Valve Body	1	32	Governor Cage	1	69	Spacer (12x8.5x1)	1
2	Valve Handle	1	33	Governor Weight	2	70	Adjusting Spacer (47x43x0.2)	1
3	Valve	1	34	Roll Pin (3x20)	2	71	Adjusting Spacer (47x43x0.5)	1
4	Valve Seat	1	35	Adjusting Spacer (13x10xt)	1	72	Washer (M12)	1
5	Band	1	36	Spring (13.3x19)	1	73	Hollico Insert (M12x1)	1
6	Handle Body Connector	1	37	Pin (H) (3x7)	1	74	Outer Snap Ring (7)	1
7	Valve Body Nut	1	38B	Exhaust Stack	1	75	Ball Bearing (6001Z)	1
8	Filter	1	41B	Screw	1	76	Ball Bearing (6201Z)	1
9	Pin (H) (3x6)	1	42	O-Ring	1	77	Ball Bearing (627)	1
10	Roller Pin (4x8)	1	47B	Housing	1	78	Ball Bearing (6204Z)	1
11	Roll Pin (2x8)	1	48	Cylinder Rear Plate	1	79	Felt Ring (28x42x5)	1
12	Spring (23x20)	1	49	Cylinder	1	80	O-Ring	1
13	Spring (40.5x25)	1	50	Rotor	1	81	Wheel Guard	1
14	O-Ring	1	51	Blade	4	82	Wheel Spindle (IN) MIO x 1.5P	1
15	Handle (Lever Type)	1	52	Front Plate	1	83	Wheel Holder Flange	1
16	Air Inlet Bushing	1	53	Cylinder Rear Plate Spacer	1	84	Wheel Nut Flange	1
17	Valve Bushing	1	54	Wheel Spindle Rear Cover	1	85	Hexagon Socket Flange	1
18	Valve Lever	1	55B	Driving Gear	1	86	Inner Snap (1RWT-17)	1
19	Valve Body Nut	1	56B	Driving Gear	1	87	SNAP Ring (21x1.2)	1
20	Safety Pin	1	57	Front Cover	1	88	Wheel Spindle (OUT) 5/8" x 11 UNC	1
21	Filter	1	58	Handle	1	89	Wheel Holder Flange	1
22	Governor Valve Bushing	1	59	Bolt (M6 x 22)	1	91	Wheel Nut Flange	1
23	Pin(H)	1	60	Nut(M6)	1	92	Allen Head Screw (M6x18)	1
24	Roil Pin (3.5x24)	1	61B	Grease Fitting	1	93	Roll Pin (3x22)	1
25	O-Ring	1	62	Spring Washer (S6)	1	95	Spanner (24x5x195)	1
26	Spring (6x18)	1	63	Spring Washer (S12)	1	96	Allen Wrench (8)	1
27	Cone Spring (10x16x16)	1	64	Snap Ring (34x1.2)	1	99	Spanner (24)	1
28	Inner Snap Ring (18)	1	65	Roll Pin (3x8)	1	100	Spanner (6x30x17)	1
29	O-Ring	2	66	Key (3x2.5x11)	1	101	Allen Wrench (4)	1
30	Governor Valve	1	67	Key (3x8)	1			
31	Governor Spindle	1	68	Spacer (47x43x1)	1			